

Name: _____	Date: _____ Event: _____
City: _____ State: _____	Track: _____
Track <input type="checkbox"/> Indoor <input type="checkbox"/> Tight <input type="checkbox"/> Smooth <input type="checkbox"/> Hard Packed <input type="checkbox"/> Blue Groove <input type="checkbox"/> Wet <input type="checkbox"/> Low Bite <input type="checkbox"/> High Bite Conditions <input type="checkbox"/> Outdoor <input type="checkbox"/> Open <input type="checkbox"/> Rough <input type="checkbox"/> Loose/Loamy <input type="checkbox"/> Dry <input type="checkbox"/> Dusty <input type="checkbox"/> Med Bite <input type="checkbox"/> Other _____	

Front Suspension

Toe: _____

Ride Height: _____

Camber: _____

Caster: _____

Sway Bar: _____

Piston/Oil: _____

Spring: _____

Limiters/Droop: _____

Overall Shock Length: _____

Steering Ackerman: _____

Bump Steer: _____

Camber Link: _____

Shock Location: _____

Receiver Battery Type: _____

Differentials

Front: Standard Smart

Spring Wire Dia: _____

Qty of Springs: _____

Ramp Plate: _____

Grease: _____

Diff Fluid: _____

Center: Standard Smart

Spring Wire Dia: _____

Qty of Springs: _____

Ramp Plate: _____

Grease: _____

Diff Fluid: _____

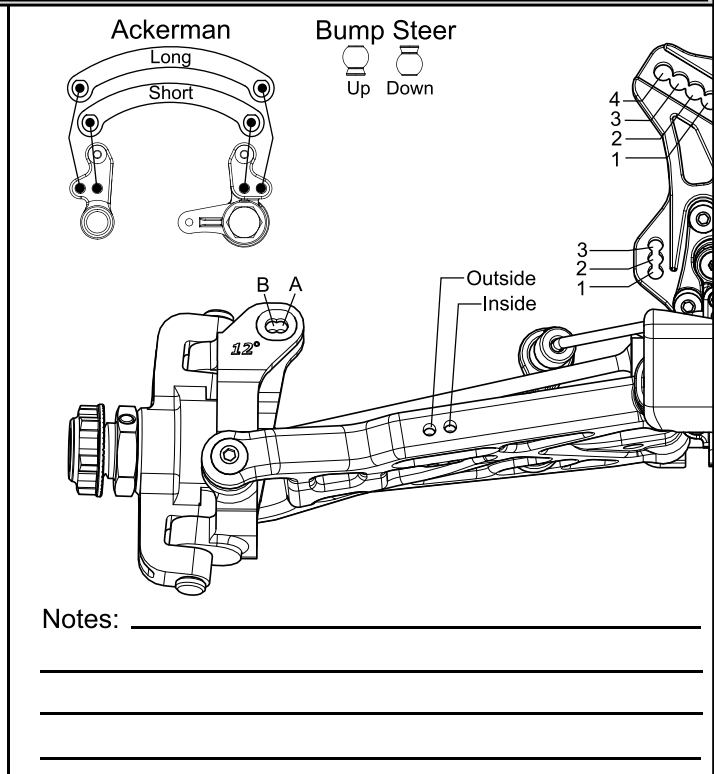

Rear Suspension

Toe: _____

Anti-Squat: _____

Ride Height: _____

Camber: _____

Rear Hub Spacing: _____

Sway Bar: _____

Piston/Oil: _____

Spring: _____

Limiters/Droop: _____

Overall Shock Length: _____

Camber Link: _____

Shock Location: _____

Rear Diff Fluid: _____

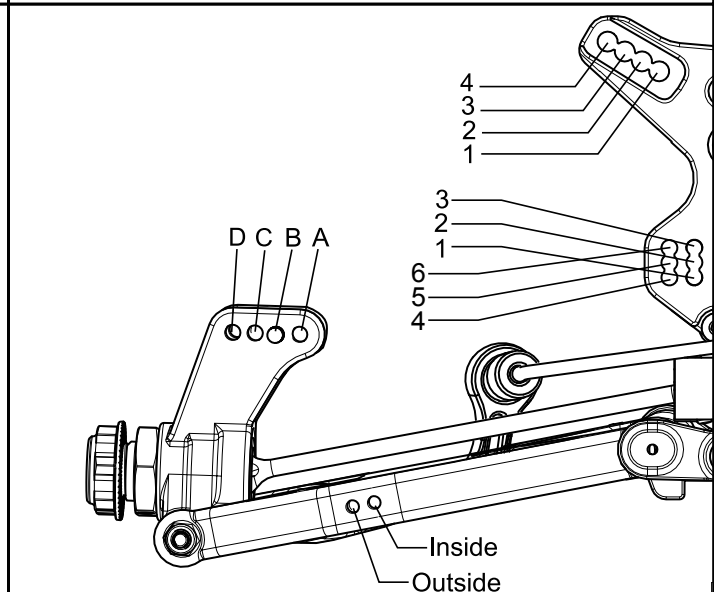

Engine

Engine: _____ Fuel: _____

Glow Plug: _____ Head Clearance: _____

Pipe/Header: _____ Gearing: _____

Clutch

Clutch Shoes and Springs Info

Tires

Type	Compound	Insert
Front: _____	_____	_____
Rear: _____	_____	_____
Notes: _____		